

# PORTABLE CRUSHING CONE CRUSHER PLANTS



## CKCCP4

- 4 ¼' Cone complete with 150 HP Low RPM Heavy Duty Electric Motor (230/460 volts, 3 phase, 60 cycle).
- 5' x 16' 3-DECK Inclined Screen. Rugged built "huck bolt design" having grease lubrication, discharge chutes, under screen hopper, 36" x 25' under screen discharge conveyor. *(optional without screen)*
- "Heavy Duty" Triple Axle Chassis. Approx. 21" I-Beam construction with heavy duty support legs in front and Rear, fifth wheel pin. All structural steel welding.
- Triple Axles with Radial Tires, Brakes, Axles, and Heavy Duty Suspension, Brake Lines, Glad Hands and Mud Flaps.
- Hydraulic Adjusting & Locking. Tramp Iron Relief.

### OPTIONAL

- Electrical Switchgear including Heavy Duty Soft Start for crusher motor, Starters and Push Buttons for each of the components on the plant. Wiring from each of the Motors to the Panel(s) when panels are plant mounted.
- New Cross Belt Self Cleaning Magnet w/ Electric Motor mounted over Main Conveyor
- (4) Four or (6) Heavy Duty Hydraulic Leveling/Stabilizing Legs.



## CKCCP3

- 3' Cone complete with 100 HP Low RPM Heavy Duty Electric Motor (230/460 volts, 3 phase, 60 cycle).
- 5' x 14' 2-DECK Inclined Screen. Rugged built "huck bolt design" having grease lubrication, discharge chutes, under screen hopper, & 36" x 25' under screen discharge conveyor. *(optional without screen)*
- "Heavy Duty" Tandem Axle Chassis. Approx. 21" I-Beam construction with heavy duty support legs in front and Rear, fifth wheel pin. All structural steel welding.
- Tandem Axles with Radial Tires, Brakes, Axles, and Heavy Duty Suspension, Brake Lines, Glad Hands and Mud Flaps.

### OPTIONAL

- Electrical Switchgear including Heavy Duty Soft Start for crusher motor, Starters and Push Buttons for each of the components on the plant. Wiring from each of the Motors to the Panel(s) when panels are plant mounted.
- New Cross Belt Self Cleaning Magnet w/ Electric Motor mounted over Main Conveyor
- (4) Four Heavy Duty Hydraulic Leveling/Stabilizing Legs.

## STANDARD FEATURES

- HEAVY DUTY proven design requires no expensive Roller Bearings. Internals of crusher are similar to that of Symons/Nordberg design. Many parts are completely interchangeable. This is a rugged machine capable of crushing some of the hardest material.
- Lubrication system with pump and tank.
- 36" wide X approx. 15' long under crusher side conveyor with impact idlers at load point. Fold up or remove for transport.
- "Operators' Platform" with Access Ladder
- Catwalks, Ladder(s), and Guarding.
- Primed and Painted with Rust Inhibiting Paint.

## ALSO AVAILABLE AS A CLOSED CIRCUIT PLANT - CKCCP4C

- 4 ¼' CONE complete with 150 HP Low RPM Heavy Duty Electric Motor (230/460 volts, 3 phase, 60 cycle). HEAVY DUTY proven design requires no expensive Roller Bearings. Internals of crusher are similar to that of Symons/Nordberg design. Many parts are completely interchangeable. This is a rugged machine capable of crushing some of the hardest material.
- Lubrication system with pump and tank.
- Complete hydraulic power pack system.
- Hydraulic Adjusting & Locking. Tramp Iron Relief.
- 6' X16' 3-deck Horizontal Screen. Complete with all chutes, under screen hopper, 42" wide X approx. 25' under screen conveyor, 40 HP, 1200 RPM high torque electric motor and drives, guarding.
- Complete Catwalks around perimeter of screen plus two (2) access ladders are included.
- 36" wide X approx. 65' Main Feed Conveyor with Skirtboard Rubber mounted on both sides of conveyor approx. 50% of length, receiving hopper, 20 HP TEFC electric motor and drives. \*The section of conveyor over the screen and cone is HINGED and/or removable for transport and to facilitate maintenance of cone and screen. Conveyor is supported with rugged tubular steel. Main feed conveyor feeds all material onto feed end of screen for pre-screening. Feed conveyor also delivers return crushed material back to feed end of screen for final sizing and discharge.
- 36" X approx. 35' Under Crusher Return Conveyor complete with 15 HP TEFC Electric Motor and Drives delivers crushed material back to main feed conveyor. Conveyor is supported by rugged tubular steel and guarded.
- Triple(3) Axle Chassis complete with Fifth Wheel Pin, Lights, Radial Tires, Brakes, Axles, and Suspension.
- Primed and Painted with Rust Inhibiting Paint.
- Plant has been constructed and built with low profile parameters for ease of transport.

### OPTIONS

- (6) SIX Heavy Duty electric/hydraulic leveling legs. Legs are designed to jack entire plant so it can be clocked while operating. Complete power pack is included and all will operate off diesel/electric power.
- Electric control panel to operate all plus (3) radial stackers not included. Panel includes separate panel for "CRUSHER DUTY" SOFT START complete with safeties and overload protection. Panels will be mounted in steel stand and removable to operate without vibration.
- Cross Belt Self Cleaning Magnet
- (4)QUAD axle chassis complete with fifth wheel pin, lights, Radial tires, brakes, axles, and suspension.

**CKCCP4 W/SCREEN 45 TONS**

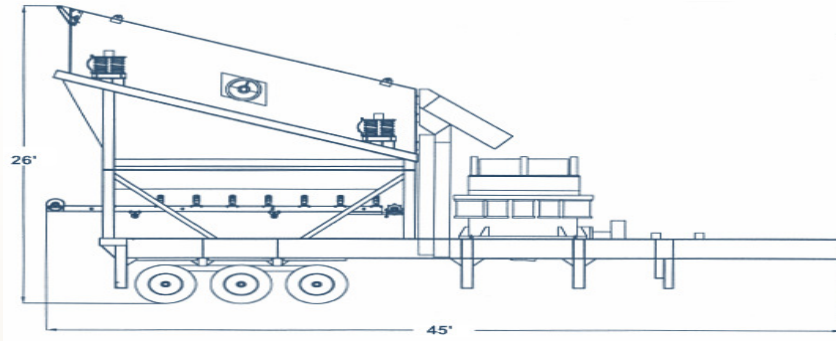

**CKCCP4C**

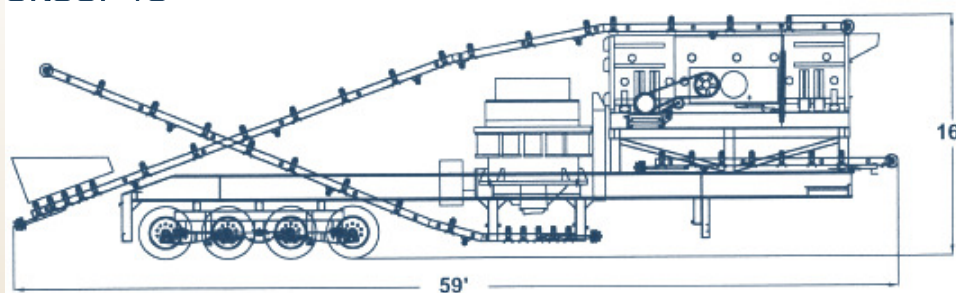

**CKCCP3 W/SCREEN 35 TONS**

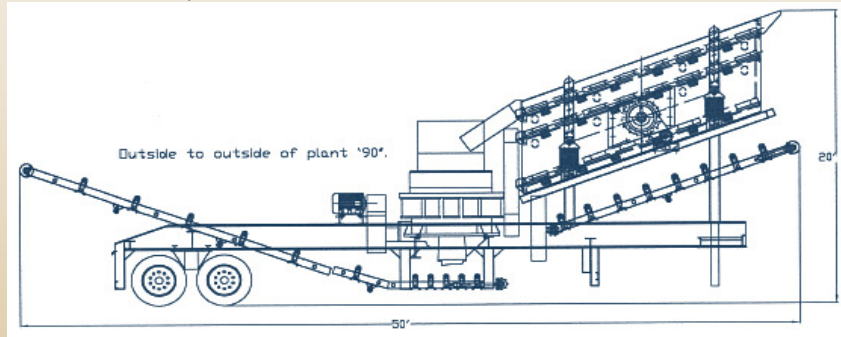

\* All photos, specifications, and/or data is approximate and subject to change without notice. Information provided in this brochure is general and for the purpose of presenting an overview of the company, its abilities, and products. Use of material without the express written consent of R.R. is strictly prohibited and subject to penalties.

MODEL	CRUSHER SIZE	FULL LOAD COUNTER-SHAFT	ELECTRIC HP	BARE WEIGHT (LBS)	BOWL, BOWL LINER WEIGHT (LBS)	HEAD, MAIN SHAFT, MANTLE & FEED PLATE ASSEMBLY WEIGHT (LBS)	COUNTERSHAFT BOX & COUNTERSHAFT ASSEMBLY WEIGHT (LBS)	ELECTRIC ASSEMBLY WEIGHT (LBS)
CKC3	3' STANDARD	580 RPM	100	22,000	4,000	3,700	2,000	1,200
CKC4	4 1/4' STANDARD	485 RPM	200	49,500	10,800	8,000	2,800	2,300



Lubrication System



Catwalk & Guarding



Cone Crushing



Heavy Duty Axles &

# THE R.R. DIFFERENCE

• **VALUE** OUR PRICES ARE UNBEATABLE

• **SAVINGS** BUY FACTORY DIRECT. NO MIDDLEMAN

• **EXPERTISE** WE INVENT, MANUFACTURE & SELL WORLDWIDE

• **VARIETY** FROM ATTACHMENTS TO COMPLETE CRUSHING PLANTS, WE OFFER THE LARGEST RANGE OF PRODUCTS TO MATCH ANY BUDGET

FOR MORE INFORMATION OR TO SCHEDULE A DEMO:  
 5550 CHARLOTTE HWY . LANCASTER, SC . 29720  
 (803)416-5200, PHONE . (803) 416-5202, FAX  
 SALES@RREQUIPMENT.COM . WWW.RREQUIPMENT.COM