

SCREENING PORTABLE WASH PLANTS



CUSTOMIZE YOUR SET-UP TO MEET YOUR NEEDS! CHOOSE A SCREEN & WASHER. WE WILL DO THE REST!

- CHOICE OF SCREENS (INCLINE OR HORIZONTAL)
5X16 - 6X20
- CHOICE OF SCREW WASHERS
(SINGLE 36, TWIN 36, TWIN 44 & TWIN 54)
- ELECTRIC AND/OR DIESEL POWER
- EASY TRANSPORT & RAPID SET-UP
- SCREEN LOWERS FOR TRANSPORT - OPTIONAL HYDRAULIC
- HIGH WATER VOLUME SLURRY BOX
- COMPLETE WATER MANIFOLD MOUNTED INDEPENDENT OF SHAKING SCREEN
- INDIVIDUAL BRASS BALL VALVES & NOZZLES ON EACH PIPE
- REMOVABLE CHUTES
- UP TO 600 TPH (TPH MAY VARY DEPENDING ON MATERIAL & CONDITIONS)
- PORTABLE SCREENS W/OUT WET SYSTEM AVAILABLE

OUR MOST POPULAR PLANT CONFIGURATIONS. **BASED ON AVERAGE YEARLY SALES.

FEATURES FOR ALL PLANTS

PLANT WILL BE CLEANED, PRIMED, PAINTED, SIDE TENSION, RAILS, ELECTRIC MOTOR AND DRIVES, MOTOR BASE, MOUNTING SPRINGS.

SCREENS COMPLETE WITH:

- WATER SPRAY BARS ON ALL THREE DECKS. SPRAY BAR AND WATER WASH SYSTEM CONSIST OF COMPLETE WATER MANIFOLD WITH BRASS BALL VALVES TO REGULATE FLOW. BRASS SPRAY JET NOZZLES DESIGNED TO SPRAY CORRECT FAN BASED ON DISTANCE BETWEEN EACH DECK.
- DISCHARGE CHUTES AND UNDER SCREEN FLUME/HOPPER FEEDING SCREW.
- COMPLETE CATWALK SYSTEM MOUNTED ON BOTH SIDES OF SCREEN WITH LADDERS AND RAILINGS.

FINE MATERIAL SCREW WASHER COMPLETE WITH:

- POSITIONING AT CORRECT ANGLE UNDER SCREEN.
- ADJUSTABLE MOTOR BASE AND ELECTRIC MOTOR WITH DRIVES.

OPTIONAL FEATURES:

- SCREEN CLOTH
- INSTALLATION OF VARIOUS LININGS IN CHUTES AND FLUME
- ELECTRIC CONTROL PANEL: EQUIPPED WITH A COMPLETE ELECTRIC CONTROL PANEL CONSISTING OF ELECTRICAL SWITCH GEAR, STOP/START BUTTONS AND WIRING FROM PANEL TO EACH INDIVIDUAL MOTOR. THE PANEL ITSELF IS ENCLOSED BY AN OUTDOOR NEMA ENCLOSURE
- HYDRAULIC RAISE/LOWER OF SCREEN BOX ASSEMBLY

SKWP5163

- 5' X 16' 3-DECK INCLINED SCREEN
- 36" X 25' FINE MATERIAL SCREW WASHER
- MOUNTED ON A HEAVY DUTY SINGLE AXLE DUAL WHEEL CHASSIS COMPLETE WITH AIR BRAKES, MUD FLAPS AND FIFTH WHEEL PIN

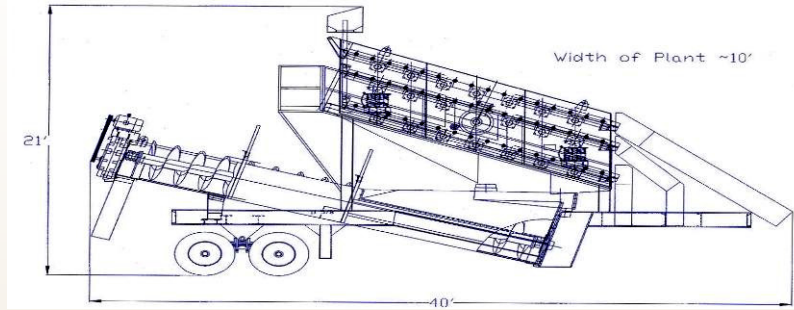

SKWP6163

- 6' X 16' 3-DECK INCLINED SCREEN
- TWIN 36" X 25' FINE MATERIAL SCREW WASHER
- MOUNTED ON A HEAVY DUTY SINGLE AXLE DUAL WHEEL CHASSIS COMPLETE WITH AIR BRAKES, MUD FLAPS AND FIFTH WHEEL PIN

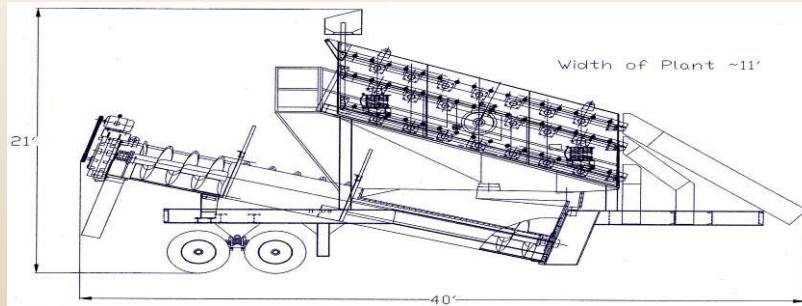

SKWP6203

- 6' X 20' 3-DECK INCLINED SCREEN
- TWIN 44" X 32' FINE MATERIAL SCREW WASHER
- MOUNTED ON A HEAVY DUTY TANDEM AXLE DUAL WHEEL CHASSIS COMPLETE WITH AIR BRAKES, MUD FLAPS AND FIFTH WHEEL PIN

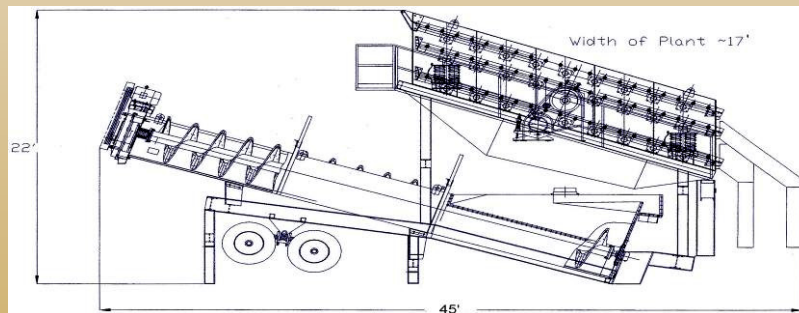

* All photos, specifications, and/or data is approximate and subject to change without notice. Information provided in this brochure is general and for the purpose of presenting an overview of the company, its abilities, and products. Use of material without the express written consent of R.R. is strictly prohibited and subject to penalties.

THE R.R. DIFFERENCE

- **VALUE** OUR PRICES ARE UNBEATABLE
- **SAVINGS** BUY FACTORY DIRECT. NO MIDDLEMAN
- **EXPERTISE** WE INVENT, MANUFACTURE & SELL WORLDWIDE
- **VARIETY** FROM ATTACHMENTS TO COMPLETE CRUSHING PLANTS, WE OFFER THE LARGEST RANGE OF PRODUCTS TO MATCH ANY BUDGET

FOR MORE INFORMATION OR TO SCHEDULE A DEMO:
5550 CHARLOTTE HWY . LANCASTER, SC . 29720
(803) 416-5200, PHONE . (803) 416-5202, FAX
SALES@RREQUIPMENT.COM . WWW.RREQUIPMENT.COM